

3D PRINTING

3D printing or additive manufacturing is a process of making three dimensional solid objects from a digital file.

What is 3D Printing?

The creation of a 3D printed object is achieved using additive processes. In an additive process an object is created by laying down successive layers of material until the entire object is created. Each of these layers can be seen as a thinly sliced horizontal cross-section of the eventual object.

The process starts with making a virtual design of the object that has to be created. This virtual design is made in a CAD (Computer Aided Design) file using a 3D modelling program (new object) or using a 3D scanner (existing object). Slicing software slices the final model into hundreds or thousands of horizontal layers. When this prepared file is uploaded in the 3D printer, the printer creates the object layer by layer. The 3D printer reads every slice (or 2D image) and proceeds to create the object blending each layer together with no sign of the layering visible, resulting in one three-dimensional object.

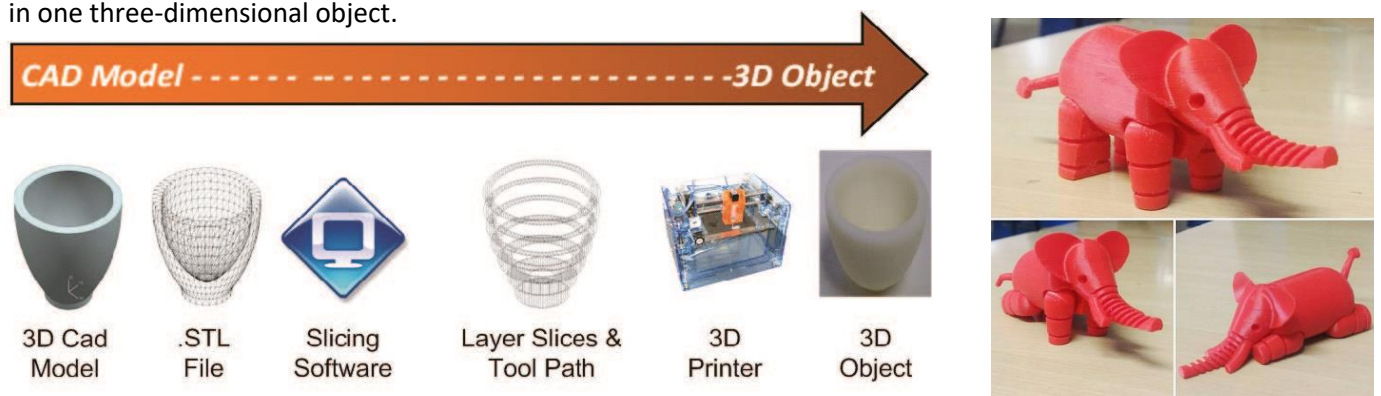

Technology used in ATIs : Fused Deposition Modelling (FDM) Technology

FDM can easily be understood as drawing with a very precise hot glue gun, by extruding material through a nozzle to print one cross section of an object (in the X-Y or horizontal plane), then moving up vertically (Z-axis) to repeat the process for a new layer, thus prints from the bottom upwards. The printer nozzle contains resistive heaters that melt the plastic as it flows through the tip and forms the layers. The extruded plastic then hardens immediately as it bonds to the layer below it.

Quality Factors - Layer height, material quality, bed level, temp., orientation, nozzle speed, feed rate.

Resolution - Range of 75 to 300 microns.

Temperature - Range of 170 and 240 degrees Celsius, depending on the type of material being used.

Material - Thermoplastics or thermoplastic/organic-material blends. ABS, PLA, polycarbonate (PC), PVA, ninjaflex. For ATIs - PLA has been a clear winner for home 3D printing because of its biodegradability, and because it does not give off unpleasant chemical fumes during the printing process.

All mentors are:

1. Expected to be aware and translate the following to their audience:

- Observe Safety norms for using a 3D printer.
- General maintenance and troubleshooting of a 3D printer.
- Demonstrate relevant expertise and teach 3D design and slicing software.

2. Suggested to:

- Choose efficient orientation of the model on print bed.
- Design and 3D print an object/component with the audience, if time permits.
- Keep the 3D printer on and working during the session for visual explanations.
- Share 'quick tips', best practices while using the additive manufacturing tools.
- Create samples of a benchmarking model at printed at different parameters and stages.
- While FDM is a very flexible printing process, it can have trouble printing sharp angles and overhangs.
- Explain post processing steps like removing rafts and supports, filing, sanding, Acetone vapour bath etc.

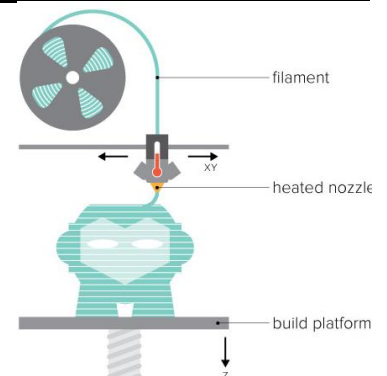

References:

The following is a non-exhaustive and suggestive list of resources on the concept of digital literacy:

| Resource Description | |
|--|----------------------|
| 3D Printing – Wikipedia | Link |
| 3D Printing – Youtube Channels | Link |
| What is 3d Printing | Link |
| 10 best 3D Printing tutorials | Link |
| Popular 3d modelling design software | Link |
| List of 3d Modeling software - Wikipedia | Link |

Note:

1. Mentors are recommended to build their content and deliver to their audience in the ATIs and not plagiarize.
2. Mentors are encouraged to explore resources and share critical observations within communities and with AIM.
3. Please note these are third party links and AIM or NITI Aayog does not endorse any person(s) or organizations mentioned on or related to these links.
4. The opinions and views expressed by the mentor during her/his interaction are of their own and do not necessarily reflect the views of AIM, NITI Aayog.
5. Mentors are aware that the engagement with the ATIs is treated as a community service and there shall be no financial transactions between any stakeholder and mentor for any official ATi related activity.